

# Pearl 3 Phono Build Notes

The Pearl 3 is the latest phono preamplifier generously offered to Do It Yourself audio enthusiasts by Wayne Colburn of Pass Labs. This circuit was first presented at the 2023 Burning Amp Festival. The Pearl 3 phono stage is a composite amplifier featuring a low noise parallel JFET front end, driving a passive-feedback, split RIAA EQ, in the loop with a bipolar output follower stage. An optional, balanced line driver can be mounted on the board for those who wish to use balanced / XLR outputs. The circuit employs several strategies to minimize noise, such as, parallel JFETs (Q1-4), an active capacitor multiplier with low noise transistor (Q8), voltage regulation (U3-4), and connections for an external/separate raw power supply. The Pearl 3 offers flexibility in parts selection allowing builders to experiment and explore options to find their preferred sonic flavor. Builders can choose between many surface mount or socketed DIP8 op amp options. Builders can also select between several surface mount or traditional through-hole front-end JFETs options.

In addition to this document, please refer to the illustrated, step-by-step build guide on DIYAudio.com.

Thank you to Wayne Colburn for designing this project, Jim “6L6” for the build guide and kits, Greg Tatarian for documentation support, and to all for their ongoing support to the DIYAudio community!

Project Difficulty: **NOVICE**

**INTERMEDIATE**

**EXPERT**



## Questions?

**You're probably not alone!**

**Post your question(s) on the DIYAudio forums.**



This project uses line/mains voltages in the power supply. The voltages in this unit can kill – even at miniscule current. If you are not competent or confident with working with these voltages, please seek advice from either a qualified electrician, or an audio DIYer who is competent and experienced in this area. Always work safe and work smart!

The PCBs and parts for this project are offered without any warranty, guarantee provided, or liability accepted by diyaudio.com, or the volunteers who bring you this project.

By building this project, you accept all liability.

Version / Date	Revision History	Author	Review
V1.0a 02 Dec 2023	Initial Release	R. Thatcher (rhthatcher)	6L6, GKTAUDIO
V1.0b 12 Dec 2023	BOM clarification, higher resolution schematics, updated testing section	R. Thatcher (rhthatcher)	6L6, GKTAUDIO

# Getting to know the PCBs

## Pearl 3 Phono PCBs – one PCB per Channel

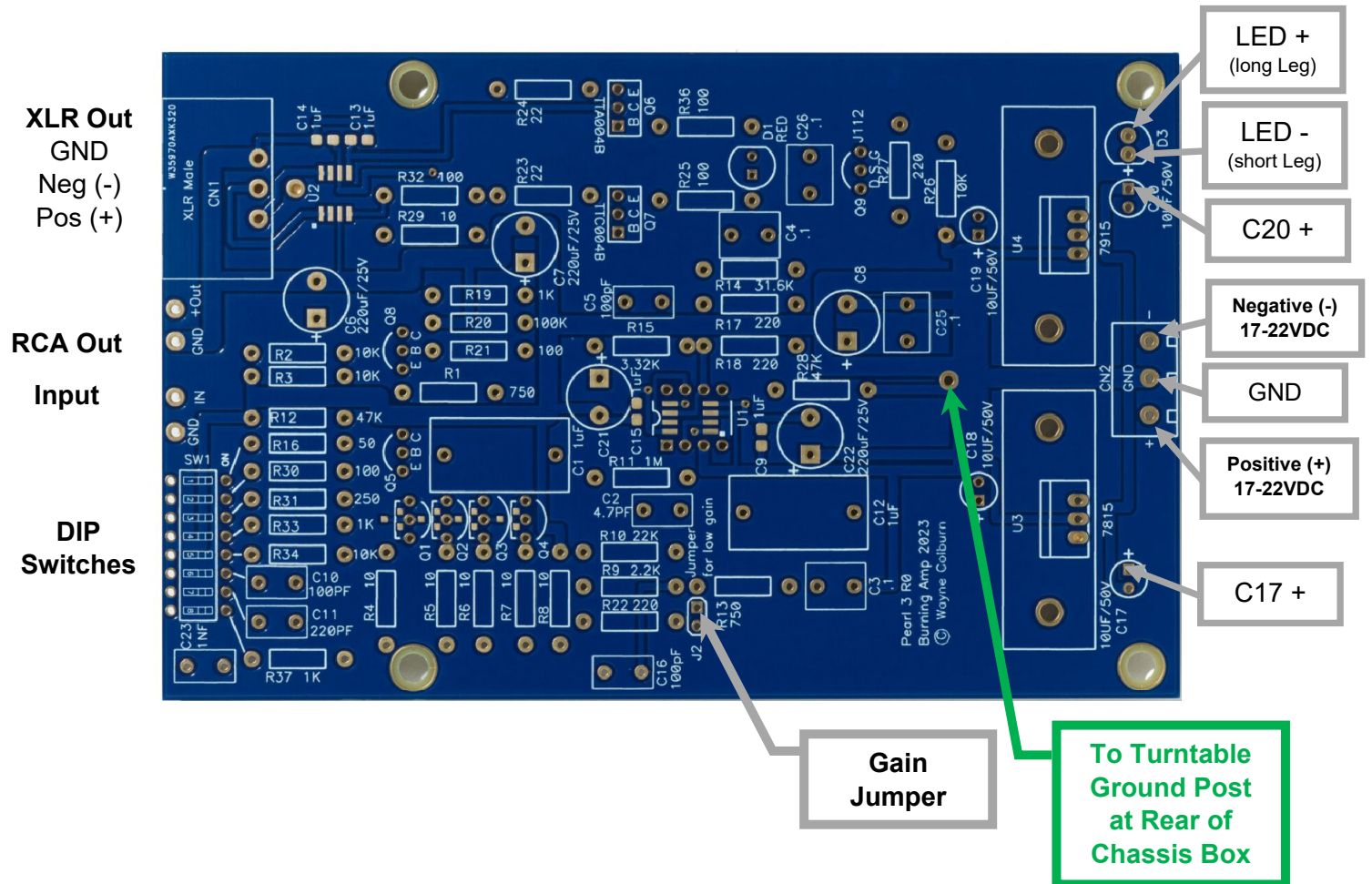

## Power Supply PCBs

The power supply PCB size is 100x100mm. Below is an overview of the PCB, showing the various sections.

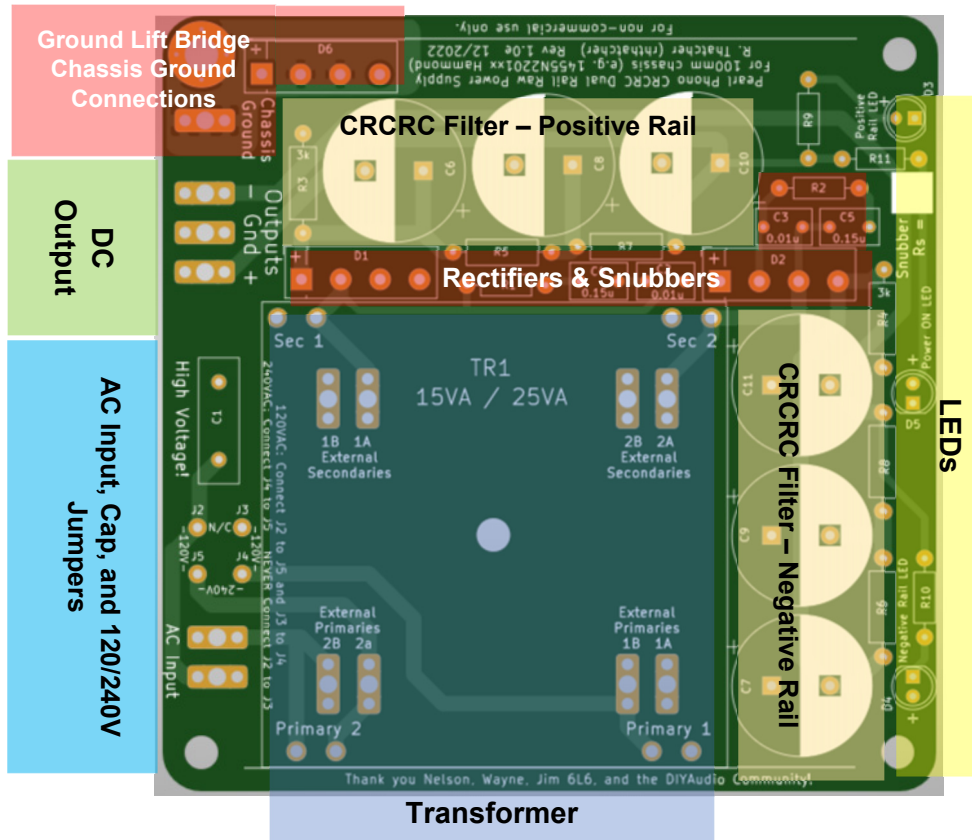

A Modushop chassis will be available for purchase from the diyaudio.com store. The power supply PCB will also fit into a Hammond Chassis (1455N1602xx or 1455N2201xx Series) with room for IEC and Switch.

## PCB Revisions

PCB	Version / Date	Revision History
Pearl 3 Phono	R0 – 10/2023	<ul style="list-style-type: none"> <li>Original Release at Burning Amp 2023</li> </ul>
Pearl Phono CRCRC Raw PSU	V1.0g – 3/2023	<ul style="list-style-type: none"> <li>Original Release</li> </ul>
Pearl Phono CRCRC Raw PSU	V1.0j – 10/2023	<ul style="list-style-type: none"> <li>Removed “external transformer” connections</li> <li>Added option for 12VA Signal Transformer split bobbin power transformer</li> <li>Added hole to secure PCB when uses ST split bobbin transformer in Hammond chassis</li> </ul>

### Pearl 3 Wiring Concept

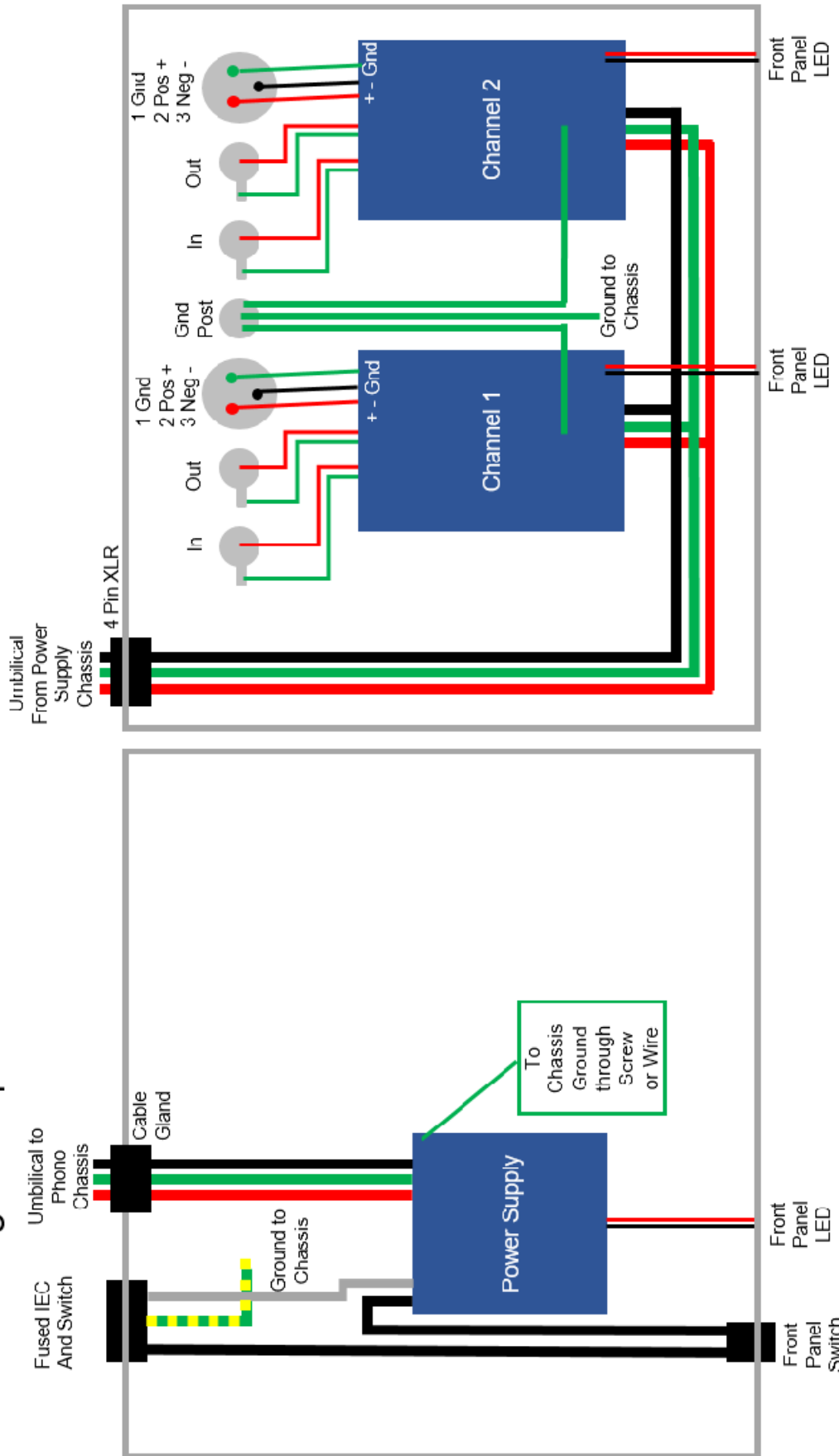

## Pearl 3 Phono Stage Parts & Notes

### Resistors

Resistors on the Pearl 3 PCBs are 1/4W rated. Use your favorite metal film resistors, e.g. Yaeko, Vishay Dale, etc.

### Capacitors

Refer to BOM for capacitors examples and values. Capacitor information worth noting:

**C8** is used to set the subsonic filtering point. Standard specified value is 220uF.

C8 Capacitor Value	Filter Frequency (3dB point)
47uF	15 Hz
100uF	7 Hz
220uF	3.2 Hz
470uF	1.5 Hz
1000uF	0.72 Hz

**C16** – Do not populate this position.

**C21, C22, C9, C15** – these caps are for power supply decoupling for the U1 op-amp. 220uF is a nominal value. Much smaller values can be successfully used, and physically smaller caps may be helpful when using larger discrete op-amps in position U1 (e.g. Burson). Just a few possible ideas: 10uF / 25V for C21/22 and 1uF C9/C15; 1uF film cap for C21/C22 and leave C9/C15 unpopulated. Note that the factory datasheet for the OPA1656 op amp calls for 0.1uF low ESR caps for power supply decoupling.

### Active Parts

**Q1-4** 2SK170 / LSK170 (TO-92) or 2SK209 / BF862 / 2SK3557 (SMD SOT-23). Use only one type or the other.

**Q5 & Q8** ZTX851. Alternates: ZTX450, 457, or 857. Another alternative is KSC1008YBU, but make sure there is no “C” in the suffix for this part because the pinout will not match the ZTX parts.

**Q6** TTA004B & **Q7** TTC004B – Bipolar output stage

**U1** can be surface-mount SOIC8 dual op amp OR DIP8 op amp. Mount EITHER the SMD OR a DIP8 socket. Op-amps that have been tested and found to work properly include: NJM2068, 5532, TL027, TL082, OPA2604, OPA1656, OPA2134, 4580, 833, LME49720. Op-amp rolling is encouraged including compatible offerings from Burson, Sparkos, etc. If trying new op amps, please post results in the build thread.

**U2** (DRV135 - SOIC8 package) is an optional line driver for balanced output; do not populate if only single-ended outputs will be used.

**U3** 7815 & **U3** 7915 – Fixed +/-15V Regulators + Heatsinks

**D3** – For power-on indication. Any color LED is OK. Blue/Cyan preferred.

NOTE: the “+” symbol is for C20, NOT D3. Note “flat spot” on D3 is for negative.



**D1 / Q9 (J112)** – Used to set bias for U1. Use the Red LED in the parts kit. Target current is 2-5mA measured across R27. Adjust R27 if necessary. Back to basics:  $V = I \times R$  Measure between 0.44V and 1.1V with voltmeter probes across R27.

V	I	R
Volts	mA	Ohms
0.44	2	220
1.1	5	220

### Unregulated DC Power Supply to Pearl 3 Boards

The Pearl 3 PCB's have on-board regulators to deliver +/-15V rails to the circuit. A separate, unregulated DC power supply should feed the Pearl 3 boards with sufficient voltage based on the typically specified 2V dropout voltage of the 7815/7915 regulators. A raw power supply in the +/- 17V to low 20V range is perfect for this project. Higher voltage is not recommended, as excessive heat will be generated.

### Setting Gain (Jumper, R9 and R22)

The Pearl 3 has a jumper to switch between low gain (MM) and high gain (MC) settings. Default settings are:  
 Jumper out = 2k2 (R9) 70dB total gain + 6dB on balanced out  
 Jumper in = 220R 49dB total gain + 6dB on balanced out

Those builders who use phono cartridges with “medium” gain may want to build with an alternate gain configuration. To set an alternate gain, use the following calculations:

Jumper Out: Gain =  $20 \times \text{Log} (R9/10) + 24 \text{ dB}$   
 Jumper In: Gain =  $20 \times \text{Log} ((R9 \parallel R22)/10) + 24 \text{ dB}$

Example Configurations:

Cartridge Output	R9	R22	R9    R22	SE Gain	Bal Gain (+6dB)
<b>Default Kit Values</b>					
High	2k2	Open (Jumper OPEN)	2k2	70dB	76dB
Low	2k2	220 (Jumper Closed)	200	49dB	55dB
<b>Alternate 64/49 Values</b>					
High	1K	Open (Jumper OPEN)	1k	64dB	70dB
Low	1K	250 (Jumper Closed)	200	49dB	55dB
<b>Additional examples with R9 = 2k2 and various R22 values</b>					
High	2k2	Open (Jumper OPEN)	2k2	70dB	76dB
Med	2k2	1k8 (Jumper Closed)	990	64dB	70dB
Med	2k2	1k (Jumper Closed)	688	61dB	67dB
Med	2k2	600 (Jumper Closed)	471	57dB	63dB
Med	2k2	370 (Jumper Closed)	317	54dB	60dB

## Grounding Concept

- Mains (AC) safety grounding is described in power supply section below.
- Twist wires from power supply/umbilical to Pearl 3 boards.
- Connect a ground wire from each Pearl 3 PCB to the turntable ground post using the ground connection as shown in the picture to the right.
- Connect a ground wire from the turntable ground post to the chassis.
- Scrape away paint/anodization from the chassis and use a star washer on the chassis ground point.
- Ensure all chassis panels are electrically connected (to reduce potential hum) by measuring zero Ohms from panels to the ground post. Scrape away paint/anodization from the panels as needed to make electrical connections.
- Refer to Wiring Concept Drawing

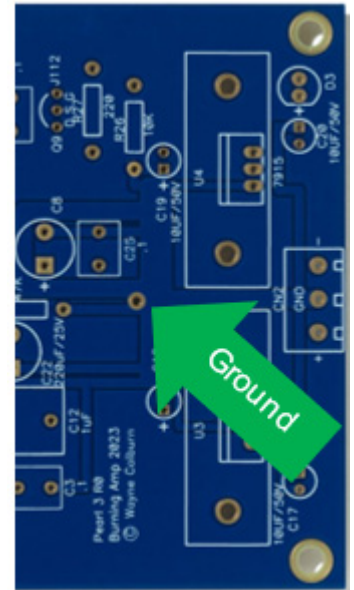

## CRCRC Power Supply Parts & Notes

### Resistors

Resistors on the CRCRC Power Supply PCB include 1/4W and 1W rated (for higher current handling).

- Use your favorite brand metal film resistors, eg. Yaeko, etc.
- Pay attention to wattage rating on BOM and Schematic.
- Higher wattage is OK, as long as the part fits on the board. Lower wattage resistors are not acceptable.
- Solder 1W power supply resistors R5-8 so that they are slightly elevated from the PCB. Put a spacer underneath them (like a piece of cardboard) to create an air gap of a few mm, then remove it after soldering them in place.

### Transformer Options

- Option 1: 60x60mm Toroidal, 15VA, 15+15V
  - Digikey stocks Amgis and Talema transformers for this application. Either will work great and fit in the 1U Modushop chassis.
- Option 2: Split Bobbin PCB mount Transformer.
  - NOTE – this transformer will NOT fit in the 1U chassis by Modushop. This transformer option is a possibility only for alternate chassis builds with a larger internal height dimension.

### Connections to PCB

You have several options for wire connections to the board including quick disconnect spades (also called PCB tabs), bare wire, or Euroblock type 5mm / 5.08 mm connectors.

### Power Supply - Setting Mains Voltage to 120 or 240V

For 120V Mains connect J2 & J5 and connect J3 & J4 with jumper wires (e.g. old resistor leads)

For 240V Mains connect J4 & J5 with jumper wires

**NEVER CONNECT J2 & J3**

### Fuse

You MUST use a fuse. Options include a fused IEC or standalone fuse holder. Suggested fuse values are in the BOM.

### Mains Grounding

Always ground IEC receptacle earth safety ground pin to the chassis! This CRCRC power supply employs a diode bridge as a ground breaker to reduce hum.

Connect “Chassis Ground” point on the PCB to chassis

- Option 1: connect a ground wire from the PCB connection point to the chassis
- Option 2: connect via metal screw between chassis and PCB.
- Use lock/star Washers for ground connections



### Unregulated DC Power Cable (Umbilical) to Phono Preamp Chassis

At a minimum you need 3 conductors (Positive, Audio Ground, and Negative) to send to the Pearl 3 chassis. Shielded cable with protective Techflex woven sheathing is preferred. Twisted 18ga stranded wire inside Techflex will also work. Standard microphone cable, such as Canare L-4E6S is a good solution.

The BOM suggests using a fixed cable in the power supply box held in place with a cable gland. The phono preamp chassis can use a connector such as a 4 PIN XLR. Do *not* use a standard 3 pin XLR which may result in connecting the power supply cable to an audio connection with potentially dangerous results. You are free to experiment with connectors on both boxes if you like.

For safety, power outputs should use female jacks. Use a female connector at end of the umbilical cable that connects to the phono chassis. If you are using a removable cable, be sure to use a female connector on the power supply chassis.

### 4-Pin XLR Wiring

XLR Pin	Power
1	Ground
2	n/c
3	Positive (+)
4	Negative (-)

### Power Supply Snubbers (Optional)

The snubber circuit is used to damp ringing between the transformer and the rectifiers. The theory and application is well described by Mark Johnson in his paper including on post #1 of the diyaudio.com thread entitled "Simple, no-math transformer snubber using Quasimodo test-jig". Using a Quasimodo test jig, one can determine the Snubber Resistor value required.

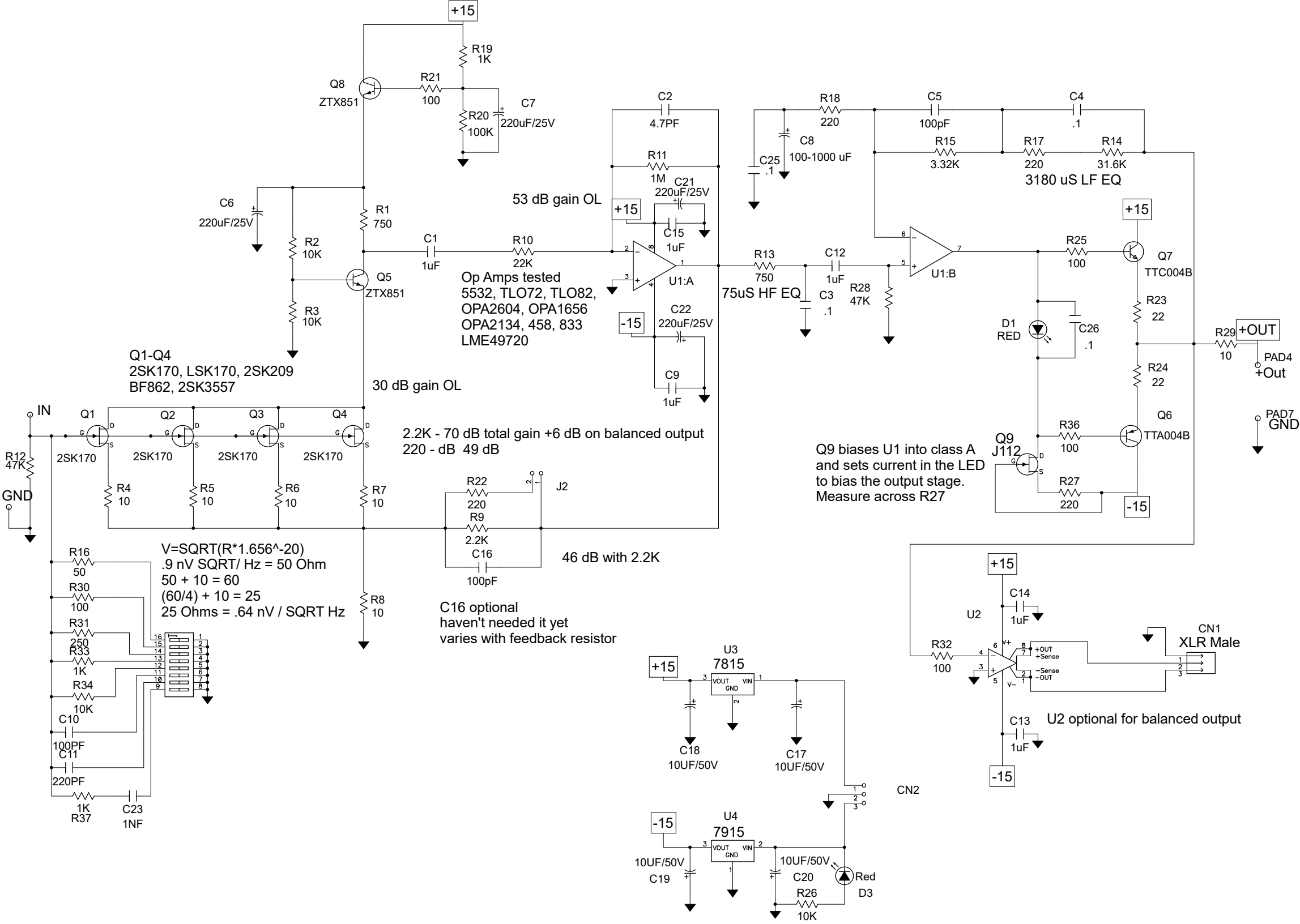

For 120V Mains connect J2 & J5 and connect J3 & J4 with jumper wires  
 For 220V Mains connect J4 & J5 with jumper wires  
 NEVER CONNECT J2 & J3

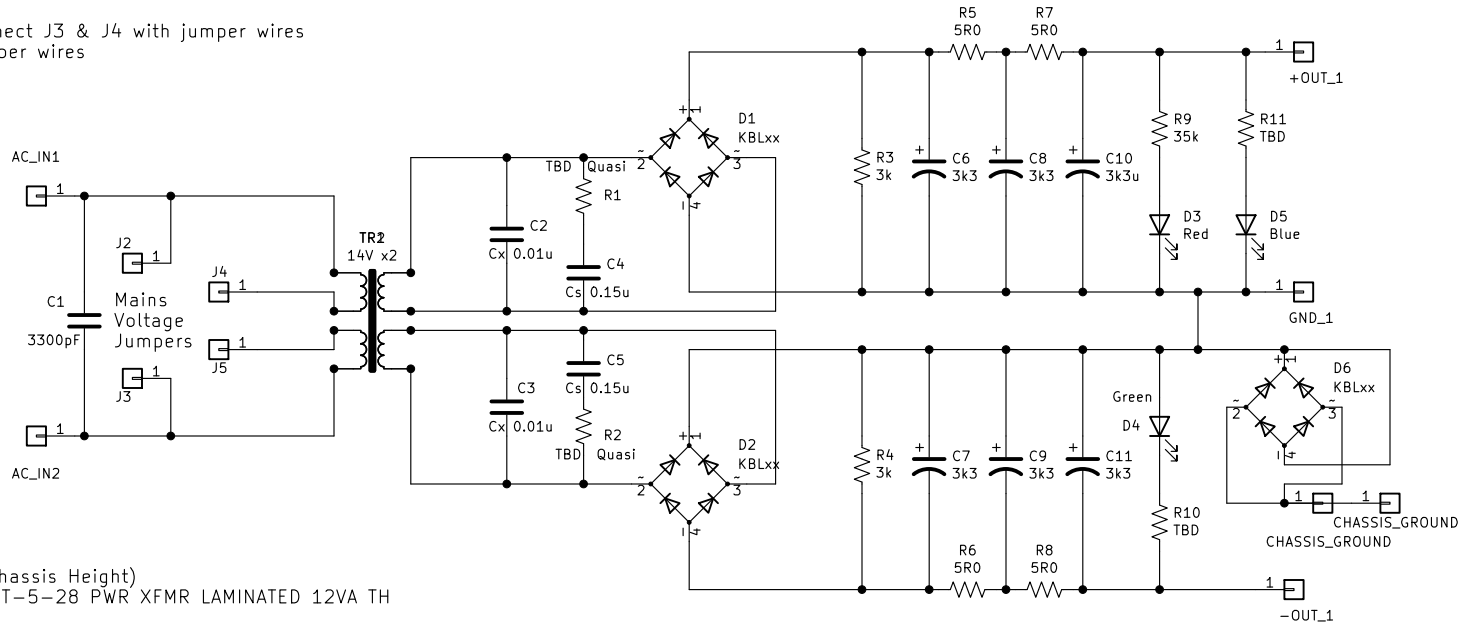

Chassis: Hammond 1455N2201xx Series  
 PCB Size 100mm x 100mm

Transformer Options  
 12VA Split Bobbin (NOTE: will not fit 1U Chassis Height)  
 595-1220-ND x1 Signal Transformer DST-5-28 PWR XFMR LAMINATED 12VA TH

15VA Toroidal Options  
 TE2253-ND x1 TR1 Amgis L01-6353 15VA/15v+15v Transformer  
 1295-1028-ND x1 Talema 70053K 15VA/15v+15v Transformer?

25VA Toroidal Options (NOTE: 25VA will not fit 1U Chassis Height)  
 TE2259-ND x1 TR1 Amgis L01-6363 25VA/15v+15v Transformer  
 1295-1023-ND x1 Talema 70063K 25VA/15v+15v Transformer

C1: 3300PF with X1 Safety Rating – Vishay VKP332MCQEJOKR or similar

Snubbers (Optional) C1-4, R1-2  
 C2, 3 (Snubber Cx) 10nF / 0.01uF EPCOS/TDK Film Cap p/n B32529C0103K289 or similar  
 C4, 5 (Snubber Cs) 150 nF / 0.15uF EPCOS/TDK Film Cap p/n B32529C0154K189 or similar  
 R1, 2 – Value TBD: Use Quasimodo Test jig. 1/4W

D1, 2, 6: KBL Series Bridge: KBL406 or similar  
 R 3, 4: Bleeder Resistors: 3k 1W  
 R 5-8: 4-10R 1W  
 Pearl 3 (25V caps) C6-11: 3k3 – 4k7 uF, 25V Electrolytic cap. 7.5mm Lead Spacing. 18mm Diameter max. Modushop 1U: 26mm Max Height. Hammond: 40mm Seated Height max.  
 R 9-11: 20k +/- 5k, 1/4W (1k / volt "rule of thumb" for LED dropper resistor)  
 D 3-5: 3 or 5MM LED. All blue, or blue for "Power On" LED, red/green for +/- rails.

Connector Options: Wire, Quick Disconnect (QD) Spades: Molex 19708-4013 or similar, or  
 2 position 5.08mm pitch terminal blocks: Phoenix Contact 1935161or similar. 3x blocks may be attached together for DC out.

Designed to fit into Modushop Pearl 3 chassis or Hammond Chassis. Fasten PCB to chassis through transformer mount hole using M4 Hardware.

Wire from "Chassis Ground" connection to chassis. Use Lock / Star washer and measure connection from PCB to chassis/earth ground on IEC to ensure connection.

Mounting holes for 10x10 grid hole spacing and M4 hardware for other Chassis options.

**Randy Thatcher (rhthatcher) Thatcher DIYAudio**

Sheet: /  
 File: Pearl2 Raw PSU-1.0j.sch

**Title: Pearl Phono Raw CRCRC Dual Rail Power Supply**

Size: USLetter Date: 2023-10-11

Rev: V1.0J

KiCad E.D.A. eeschema (5.1.7)-1

Id: 1/1

Thank you to Nelson Pass, Wayne Colburn, Jim "6L6", and the DIYAudio Community!

Not for commercial use.

**Pearl 3 Phono BOM**

This table contains example part numbers and part recommendations. Any good quality, similar parts will work with no detriment to the sound. 1 PCB per channel, so pay attention to the Quantity columns

Per PCB	Qty 2 Chan	Reference	Value	Lead Spacing	Notes	Example PN#	In Kit?
2	4	C1, C12	1.0uF	15mm		ECW-FE2W105K	Y
1	2	C11	220pF	5mm		FKP2G002201D00JSSD	Y
0	0	C16 - Do not populate	220pF	5mm			Y
4	8	C17 C18 C19 C20	10uF/50V	2.5mm		UKT1E100MDD1TD	Y
1	2	C2	4.7pF	5mm		C410C479D1G5TA7200	Y
1	2	C23	1nf	5mm		PHE426DJ4100JR05	Y
4	8	C3 C4 C25 C26	0.1uF	5mm		PHE426HJ6100JR05	Y
2	4	C5 C10	100pF	5mm		FKP2G001001D00JSSD	Y
5	10	C6 C7 C8 C21 C22	220uF/25V	5mm		EEU-FM1E221BJ	Y
4	8	C9 C13 C14 C15	1uF	SMD 0805		CL21B105KAFNNE	Y
1	2	CN2 Connector	3 Position	5mm		TB001-500-03BE	Y
1	2	D1	LED - Red	2.5mm		LTL-1CHE	Y
1	2	D3	LED - any color	2.5mm			Y
1	2	J2	Jumper	2.54mm			Y
4	8	Q1 Q2 Q3 Q4	2SK170	T092_3	Stuff only one set of Jfet	2SK170BL	Y
4	8	Q10 Q11 Q12 Q13	2SK209	SOT-23		2SK209GR	Y
1	2	Q5	ZTX851	T092_3	Alt: ZTX450/457	ZTX851	Y
1	2	Q8	ZTX457	T092_3	Alt: ZTX450/851	ZTX457	Y
1	2	Q6	TTA004B	TO-126V		TTA004B	Y
1	2	Q7	TTC004B	TO-126V		TTC004B	Y
1	2	Q9	J112	T092_3		J112	Y
2	4	R1 R13	750 R	12.7mm (0.5")		RN55D7500FRE6	Y
1	2	R10	22K	12.7mm (0.5")		SFR2500002202FR500	Y
1	2	R11	1M	12.7mm (0.5")		SFR2500001004FR500	Y
2	4	R12 R28	47K	12.7mm (0.5")		RN55D4702FRE6	Y
1	2	R14	31.6K	12.7mm (0.5")		RN55D3162FB14	Y
1	2	R15	3.32K	12.7mm (0.5")		RN55C3321FRE6	Y
1	2	R16	50 R	12.7mm (0.5")		SFR2500004999FR500	Y
4	8	R17 R18 R22 R27	220 R	12.7mm (0.5")		SFR2500002200FR500	Y
3	6	R19 R33 R37	1K	12.7mm (0.5")		SFR2500001001FR500	Y
4	8	R2 R3 R26 R34	10K	12.7mm (0.5")		SFR2500001002FR500	Y
1	2	R20	100K	12.7mm (0.5")		SFR2500001003FR500	Y
5	10	R21 R25 R30 R32 R36	100 R	12.7mm (0.5")		SFR2500001000FR50	Y
2	4	R23 R24	22 R	12.7mm (0.5")		SFR2500002209FR500	Y
1	2	R31	250 R	12.7mm (0.5")		SFR2500002490FR500	Y
6	12	R4 R5 R6 R7 R8 R29	10 R	12.7mm (0.5")		SFR2500001009FR500	Y
1	2	R9	2.2K	12.7mm (0.5")		RN55D2201FB14	Y
1	2	U1 DIP8	OPA2604	DIP8	Choose SMD or DIP8	NJM2068D	Y
1	2	U1	DIP8 Socket	DIP8		1-2199298-2	Y
1	2	U1 SMD	OPA1656	SOIC8		OPA1656	No
1	2	U2 (Optional)	DRV135	SOIC8	For XLR Out	DRV135UA	No
1	2	U3	7815	TO-220		L7815CP	Y
1	2	U4	7915	TO-220		L7915CP	Y
2	4	U3 U4 Hardware	M3 bolt + Kepnut				Y
2	4	U3 U4 Heatsink	1"			531002B02500G	Y
1	2	SW1	DIP switch 8pos			206-8ST	Y
1	2	RCA Jacks - Black				NYS367-0 (Black)	No
1z	2	RCA Jacks - Red				NYS367-2 (Red)	No
1	2	XLR (Optional)				568-NC3MD-LX-B	No
1	2	XLR Dummy Plate			If not using XLR	DBA-BL	No
1	1	Ground Post				111-0703-001	No
1	1	4 Pin XLR male Jack			Umbilical Pwr Jack	568-NC4MD-LX-B	No
		Misc - Standoffs / Hardware					No

**Power Supply BOM (1 Power Supply PCB required for 2 channels)**

Qty	Designation	Description	Add'l Detail / Comment	Digikey	Mouser
1	C1	3300pF, X1 Safety Rated	AC voltage must be rated above mains voltage	399-9501-1-ND	80-C941U332MVVDBAP
2	C2-3	FILM 10000pF / 10nF / .01uF	OPTIONAL: Snubber Cap	495-4975-1-ND	871-B32529C3103J189
2	C4-5	FILM 150nF / .15uF	OPTIONAL: Snubber Cap	495-77011-1-ND	871-B32529C3154K189
6	C6-11	2.200 - 4,700 uF / 25V	Up to 18mm Diameter, 7.5mm Lead Spacing Modushop 1U Chassis – Max Height 26.5mm Hammond Chassis: Max 40mm High	478CKE025MQV-ND	598-478CKE025MQV 647-UVK1E472MHD 871-B41858C5398M 871-B41858C5228M 647-URZ1E222MHD1TN
2	R1-2	TBD 1/4W Resistor	OPTIONAL: Snubber Resistor. Use Quasimodo	TBD	TBD
2	R3-4	3k 1W	PCB Holes - 12.7mm Lead Spacing	PPC3.0KW-1CT-ND	594-5073NW3K000J
4	R5-8	4-10R 1W	PCB Holes - 12.7mm Lead Spacing	PPC4.7W-1CT-ND	594-5073NW4R700J
3	R9-11	Pearl 3: 20k 1/4W +/- 5k will work.	LED Dropping Resistor. "Rule of Thumb" - 1k Ohm per PSU volt.	13-MFR-25FTE52-24K9CT-ND%	603-MFR-25FTE52-24K9
3	D1, 2, 6	Diode Bridge - KBL Package	KBL404, KBL406 or similar	641-2007-ND	750-KBL404-G
3	D3-5	LEDs	3 or 5MM LED. All blue/cyan, or blue/cyan for "Power On" LED, red/green for +/- rails.	Get a big assortment pack on Amazon. Or Cyan 754-2183-ND	CYAN 604-WP7113VRCBCA
1	TR1	15x2 V Transformer	15VA Toroidal Options	TE2253-ND 1295-1028-ND	Not for sale at Mouser
		14x2 V Transformer	12VA Split Bobbin <b>NOTE: Will not fit in 1U chassis. Alternate for different chassis builds only.</b>	595-1220-ND	530-DST-5-28
1	Fuse	200mA / 250V Slow Blow	12-15 VA / 120V Mains	507-1240-ND	530-5ST200-R
		100mA / 250V Slow Blow	12-15 VA / 240V Mains	507-1238-ND	530-5ST100-R
1	Terminal Block - Optional	2 Position Terminal Block - 5.08mm Pitch	Euroblock for AC Inputs (Optional)	277-1667-ND	651-1935161
1		3 Position Terminal Block - 5.08mm Pitch	Euroblock for Outputs (Optional)	102-6135-ND	TB001-500-03BE
1	Cable gland	Cable Gland Thermoplastic M16x1.5 Black	For fixed Umbilical Cable	137-CGM16N35-ND	502-CGM16N35
1	IEC	IEC with Filter	Schurter DD12.9111.1111	486-1302-ND	693-DD12.9111.1111
1	IEC	IEC Fuseholder	Schurter 4301.1405	486-1956-ND	693-4301.1405
1	Switch		SPST	100SP1T1B1M1QEHE	
1	Umbilical	4 Pin XLR Female	XLR Female connector for Cable	Not for sale at Digikey	568-NC4FXX-B
1	Umbilical	Cable	3 conductors + optional shield	Mogami W2549 Canare L-4E6S	
1	Umbilical	Cable Dressing	Techflex - pick a color you like		
1	Misc	M4 Screw + Lock Washer	Transformer to Chassis Connection		
1	Misc - Lot	Screw, Nut, Washer, Lock, "eye" terminations	For Chassis ground Connection		

## Building Notes

Refer to the illustrated, step-by-step build guide on [DIYAudio.com](http://DIYAudio.com) prepared by esteemed DIY enthusiast Jim “6L6”

General wisdom is to install and solder the items “lowest” on the board first, then move to the next highest components, following this order:

- Surface Mount Devices (SMDs)
  - Check connections when done installing by “ringing” or measuring resistance from SMD “legs” to the next point on board/schematic. Reflow any open connections now. It’s far easier to do this when only SMDs are on the board!
- Resistors
- Capacitors
- Active devices
- Connectors / Sockets
- When boards are done, wire it up (refer to wiring diagram)
  - Twist wires
  - Scrape back anodization and/or paint for chassis ground connections. Every chassis panel should be in continuity to ground.

## Testing

Action / Test	Measure	Result	Target
<b>Wiring Test – Mains not connected / POWER OFF!</b>			
Power Wiring check from PSU out to Phono Stage. Power supply power OFF, Umbilical Connected Measure Resistance from PSU output to each Phono PCB power input connector.	+ to +		0 Ohms
	Gnd to Gnd		0 Ohms
	- to -		0 Ohms
Disconnect umbilical			
<b>Power Up Tests</b>			
Power up PSU, umbilical disconnected	Smoke Test	Pass / Fail	No Smoke, LED(s) ON
Power Supply Positive Rail	Gnd to +	V	20V +/- few volts
Power Supply Negative Rail	Gnd to –	V	-20V +/- few volts
Power Down PSU			
Connect Umbilical to Phono Stage Box, Power Up PSU Voltage Check at Phono Stage PCBs	Gnd to +	V	20V +/- few volts
	Gnd to –	V	-20V +/- few volts
<b>Phono Stage Test &amp; Setup</b>			
U1 Bias – measure voltage across R27, calculate current. See below.	R27 – Left		2-5 mA
	R27 – Right		2-5 mA
Make initial DIP Switch / Jumper settings			
Play Music & Enjoy!!!			

**U1 Bias notes.** Remember Ohm’s Law  $V = I * R$  Therefore,  $I = V / R$   
 Assume 220R resistor in R27 position.  
 $V = I * R = 2mA * 220R = 0.44V$  and  $V = I * R = 5mA * 220R = 1.1V$   
 If you measure between 0.44V and 1.1V with R27 = 220R – you’re good to go.



**Georg Ohm**

**Adjustment Example:** Measure 2.4V with 220R. Calculated current is  $2.4V / 220R = 10.9mA$ . You can see that current is about 2x the spec, so you need about 2x the resistance to get current down to spec. Is there a 400-500R resistor in the parts bin? Let’s try a 549R, seems pretty close. Measured result is 2.7V. Bias current =  $2.7V / 549R = 4.9mA$  Now it’s in spec! Time to play music!

## Adjusting Settings for Operation

**MUTE preamp before adjusting these settings to avoid loud pops.**

### Jumper

Jumper	Value
Installed	Low Gain
Not Installed	High Gain

### DIP Switches

DIP Switch	Function	Value
1	Resistive Cartridge Loading	50 Ohms
2		100 Ohms
3		250 Ohms
4		1k Ohms
5		10k Ohms
6	Cartridge Capacitance Loading	100pF
7		220pF
8	Zobel for HPMC	1k Ohm + 1nF

Cartridge resistive loading is adjustable and can be calculated using the parallel resistor formula based on the baseline, installed 47k Ohms (R12) in parallel with resistor values for DIP switches 1-5 that are turned on. When DIP switches 1-5 are in the OFF position the cartridge load is 47k Ohms. The table below shows values for various DIP switch settings and the associated loading values in the left-hand column:

Switch Number	1	2	3	4	5
Load R	50	100	250	1000	10000
Cart Load (Ohms)					
29	ON	ON	ON		
33	ON	ON			
48	ON			ON	
50	ON				
67		ON	ON	ON	
71		ON	ON		
91		ON		ON	
100		ON			
195			ON	ON	ON
199			ON	ON	
243			ON		ON
249			ON		
892				ON	ON
979				ON	
8246					ON
47000					

Capacitor loading is calculated using parallel capacitor loading formula. The table below shows values for various DIP switch settings and the associated loading values in the left-hand column:

Switch	6	7
Capacitance	100pF	220pF
0 pF		
100pF	ON	
220pF		ON
320pF	ON	ON